

SYNTHESIS OF DEUTERIUM-LABELLED DICLOFENAC SODIUM

D. LEROY*, J. RICHARD and J. GOBBILLON

Laboratoires Ciba-Geigy, Biopharmaceutical Research Center,
B.P. 308, 92506 RUEIL-MALMAISON Cédex (FRANCE)

SUMMARY

Diclofenac sodium labelled with deuterium in the phenylacetic ring was prepared from [²H₅]-bromobenzene in a six-step reaction. It was found to be suitable for use in pharmacokinetic and bioavailability studies in man.

KEY WORDS : Diclofenac, deuterium-labelling, non-steroidal anti-inflammatory drug.

INTRODUCTION

Diclofenac sodium (o-[(2,6-dichlorophenyl)amino]phenyl sodium acetate), the active ingredient of VOLTAREN[®] is a non-steroidal anti-inflammatory drug (NSAID) used in the treatment of rheumatic diseases.

(*) To whom any correspondence should be addressed.

The in vivo use of stable isotopes has proved to be a powerful tool for pharmacokinetic investigations or bioavailability studies (1, 2, 3, 4). The lack of toxicity of stable isotopes make them ideally suited for human studies. In addition, they eliminate the risk of radiation exposure accompanying radioactive tracers.

In order to evaluate peculiar kinetic properties of diclofenac, as well as new topical formulations, using the stable isotope methodology (i.e. simultaneous administration of labelled and non-labelled drug), diclofenac sodium labelled with deuterium atoms was prepared.

The synthetic procedure was derived from that described for the preparation of [^{14}C]-diclofenac by Stierlin et al. (5). Starting from 2,6-dichloroaniline 1, deuterium atoms were introduced by using [$^2\text{H}_5$]-bromobenzene as solvent and reagent in the second step (scheme I).

Hydrolysis of the phenylacetamide 3, then addition of chloroacetyl chloride gave the phenyl chloroacetamide 5. Cyclisation of 5 by aluminium chloride yielded the indolinone 6 which was hydrolyzed to diclofenac acid 7. This later was converted into its sodium salt 8.

In order to apply the stable isotope methodology, large amounts of highly pure [$^2\text{H}_4$]-diclofenac sodium were needed. Special cares, in relation with appropriate tests, were taken to achieve the required purity of the labelled material.

EXPERIMENTAL

[$^2\text{H}_5$]-bromobenzene with 99 % isotopic purity was purchased from C.E.A. (Saclay, France). All the solvents and reagents were of analytical grade.

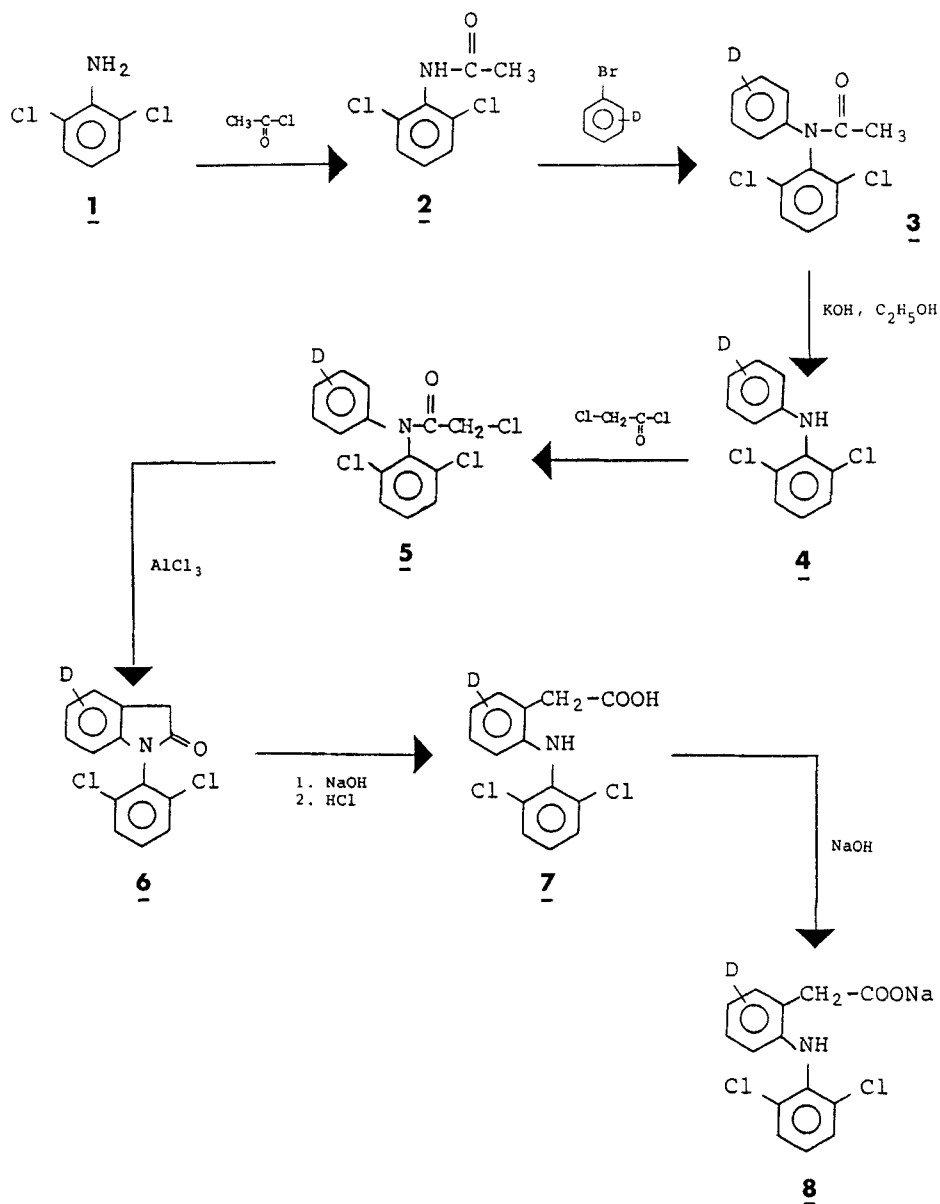
Scheme I : Synthesis of [2H₄]-diclofenac sodium.

Thin layer chromatographic analyses were conducted using silicagel 60F₂₅₄ TLC plates (Merck). The compounds were revealed by U.V. detection. ¹H-NMR spectra were recorded at 60 MHz on a Jeol PMX60 NMR spectrometer using tetramethylsilane as standard.

I.R. spectra were recorded on a Philips PU 9716 spectrometer. Gas chromatography - mass spectrometric (GC-MS) analyses were carried out using a system consisting of a Varian gas chromatograph interfaced with a Ribermag (model 10-10) MS instrument. A glass column (1 m x 2 mm i.d.) packed with 3 % OV17 on Gas chrom Q was used. The chromatographic parameters were, carrier gas : helium ; column temperature : 250°C ; injection port and interface temperature : 260°C. Chemical ionisation (CI) with ammonia and positive ion detection were performed. Deuterium incorporation was determined by selected ion monitoring of parent ions of the dimethyl indolinone derivative prepared by the method of Schneider et al. (6,7), m/z 310 [²H₄], m/z 309 [²H₃], m/z 308 [²H₂], m/z 307 [²H₁], m/z 306 [²H₀]. HPLC analyses were performed on a Hewlett Packard 1084 liquid chromatographic system with a U.V. detector set at 282 nm. The reported melting points determined on a Büchi 535 apparatus were uncorrected.

N-acetyl-2,6-dichloroaniline (2).

Acetyl chloride (40 g, 509 mmol) was added dropwise to a solution of 2,6-dichloroaniline (1) (81 g, 500 mmol) in glacial acetic acid (30 ml). The reaction mixture was refluxed at 70°C for 30 min, poured onto crushed ice (300 g) and stirred at room temperature for 1 hour. The crude product crystallized out ; it was filtered and recrystallized from a 50 % acetic acid solution to afford 80 g (yield : 78 %) of 2 as a white powder.

Melting point = 178°C.

R_f (CHCl₃ - petroleum ether 50:50) = 0.38.

I.R. (Nujol) : 3220 cm⁻¹ (νN-H), 1670 cm⁻¹ (νC=O), 1540 cm⁻¹

$\begin{array}{c} \text{O} \\ || \\ (\nu\text{-C-NH}). \end{array}$

N-(2,6-dichlorophenyl)-[²H₅]-phenylamine (4).

Five batches of 4 were successively prepared. Each batch was

obtained as follows : N-acetyl-2,6-dichloroaniline (2) (6.7 g, 32.6 mmol), potassium carbonate (3 g, 21.7 mmol), copper powder (250 mg) and [²H₅]-bromobenzene (100 g, 617 mmol) were mixed and refluxed at 160°C for four days. The reaction mixture was filtered ; the filtrate was concentrated to about 50 ml under reduced pressure, and diluted with diethyl ether (50 ml). 2,6-dichlorophenyl-[²H₅]-phenylacetamide (3) obtained after filtration and concentration to about 10 ml, was then hydrolyzed by adding a 10 % ethanolic solution of potassium hydroxide (30 ml). The mixture was refluxed at 90°C for 2 hours. Evaporation of the solvent, followed by distillation of the dry residue in a bulb tube at 90-180°C under 40 Pa gave a solid product. Crystallization from hexane gave 3.6 g (yield : 45 % from 2) of pure 4. After pooling all the batches, 23 g of 4 were obtained.

Melting point = 48-49°C.

Rf (CHCl₃ - petroleum ether 50:50) = 0.87.

I.R. (Nujol) : 3290 cm⁻¹ (νN-H).

EIMS : m/z 242 (M⁺).

2-chloro-N-(2,6-dichlorophenyl)-N-[²H₅-phenyl]-acetamide (5).

Chloroacetyl chloride (13 g, 115 mmol) was added dropwise to 4 (4.6 g, 19 mmol) under nitrogen. The mixture was stirred for 1.5 h at 140°C, then glycol monoethyl ether (10 ml) was added ; stirring was maintained at 140°C for 1 h. After cooling and addition of toluene (70 ml), the organic phase was washed with a saturated aqueous solution of potassium bicarbonate (4 x 100 ml). The organic layer was dried and evaporated to dryness. The residue was crystallized from chloroform-petroleum ether (50:50) to yield 4.9 g (81 %) of 5. After pooling all the batches, 23 g of 5 were obtained.

Melting point = 141-142°C.

Rf (CHCl₃ - petroleum ether 50:50) = 0.63.

EIMS : m/z 318 (M⁺).

1-(2,6-dichlorophenyl)-2-[²H₄]-indolinone (6).

5 (4.6 g, 14.4 mmol) and aluminium chloride (5.8 g, 43.4 mmol) were mixed and stirred under nitrogen at 150°C for 2 h. The reaction mixture was poured onto crushed ice and treated in toluene (70 ml). The organic layer was washed with a saturated solution of sodium bicarbonate (3 x 100 ml), dried and evaporated to dryness. The residue was distilled in a bulb tube at 160-170°C under 40 Pa.

Crystallisation from dichloromethane - petroleum ether (50:50) yielded 3.2 g (79 %) of 6. After pooling all the batches, 17 g of 6 were obtained.

Melting point = 120-122°C.

R_f (CH₂Cl₂) = 0.44.

I.R. (Nujol) : 1740 cm⁻¹ (νC=O).

CIMS : m/z 282 (MH⁺).

Sodium salt of o-[(2,6-dichlorophenyl)amino]-[²H₄-phenyl]-acetic acid (8).

A solution of 6 (3.4 g, 12 mmol) in ethanol (16 ml) was refluxed for 4 h at 90°C with an aqueous solution of 5 M sodium hydroxide (12 ml). After addition of water (100 ml), extraction with dichloromethane (3 x 100 ml) and acidification of the aqueous layer with an aqueous solution of 5 M hydrochloric acid (30 ml), diclofenac precipitated as free acid (7). The product was extracted with diethyl ether. The dry residue obtained after evaporation of the solvent was dissolved in an aqueous solution of 1 M sodium hydroxide (40 ml) at 60°C. After cooling to room temperature, labelled diclofenac sodium precipitated. The crude product was filtered and dried to give 6.1 g (yield : 80 %) of 8.

RESULTS AND DISCUSSION

- Ⓐ After pooling all the batches, 14.6 g of 8 were obtained.
- . Melting point : 280°C with decomposition.
 - . T.L.C. :
 - water - butanol-ethyl acetate-methanol-10 % ammonia solution
1:30:25:20:10, R_f = 0.8
 - toluene-formic acid-hexane
80:12:8, R_f = 0.6
 - . HPLC (Methanol - buffer pH 7 60:40, RP-8 10 μm) t_R = 4.5 mn.
 - . I.R. (KBr) : 3380 cm⁻¹ (νN-H), 1580 cm⁻¹ (νC=C arom, νCO₂⁻),
1400 cm⁻¹ (νCO₂⁻).
 - . ¹H NMR ((CD₃)₂SO) : δ3.4 (s, 2H, CH₂), 6.3 - 7.6 (m, 3H, 3,4,
5 ArH), 10 (s, 1H, NH).
 - . Analysis calculated for C₁₄H₆²H₄Cl₂NO₂Na·0.25H₂O (326.67) :
C, 51.47 ; H, 1.85 ; N, 4.29 ; Cl, 21.71
Found : C, 51.01 ; H, 1.92 ; N, 4.28 ; Cl, 21.71
 - . CI Mass spectrum of the dimethyl indolinone derivative (m/z
310 (MH⁺)) showed isotope distribution as follows : ²H₀,
1.1 % ; ²H₁, 6.6 % ; ²H₂, 19.6 % ; ²H₃, 36.2 % ; ²H₄, 36.4 %.
The mass spectra of the various intermediates showed that
deuterium-hydrogen exchanges occurred at different steps,
essentially during the cyclization in presence of aluminium
chloride to the compound 6.
The acute toxicity in mice of the labelled compound was found
to be comparable to that of the unlabelled drug.
The simultaneous administration of equal doses of labelled and
non-labelled diclofenac-Na as a single oral solution showed
that the kinetics of both compounds were identical. The
labelling did not induce in vivo isotope effects.
A TLC control after a long term storage revealed that the
batch contained unknown by-products at a level (0.5-1 %)

higher than required (maximum 0.2 %) in the current specifications of purity for the active ingredient. A purification step was therefore performed.

Ⓔ Purification step and purity control : 8.9 g (27.6 mmol) of 8 were submitted to repeated crystallizations from methanol-diethyl ether to give 8 g (24.8 mmol) of pure deuterium-labelled diclofenac sodium.

This batch was compared to an authentic reference sample of diclofenac sodium using T.L.C. controls according to an internal procedure.

Plates : Merck Silicagel 60F₂₅₄

(20 x 20 cm, layer thickness 0.25 mm)

Solvent system : toluene - n-hexane-formic acid (20:2:3).

The tank was fitted with a filter paper and formic acid was first uniformly layered on the paper. In a second time, the mixture toluene - n-hexane was uniformly layered on the paper. Saturation was performed during 30 min.

Spotting : Solutions of labelled and unlabelled diclofenac sodium were prepared in methanol. 2 μ l (100 μ g) of each solution were spotted. The migration was performed during 30 min up to 13 cm. The plates were dried under a cold draught during 10 min.

Detection : UV 254 nm, immediately after drying - R_f : 0.4.

Purified deuterium-labelled diclofenac sodium containing less than 0.1 % of unknown by-products fully met the current specifications for the active substance. This compound was

suitable for additional pharmacokinetic investigations following topical application of a single dose in man. It was used too as an internal standard for GC-MS determination of diclofenac (8).

REFERENCES

1. Baillie T.A. - Pharmacol. Rev. 33:81 (1981).
2. Wolen R.L. - J. Clin. Pharmacol. 26:419 (1986).
3. Karlsson M.O. and Bredberg U. - J. Pharmacokin. Biopharm. 18:103 (1990).
4. Brown T.R. - Clin. Pharmacokin. 18:423 (1990).
5. Stierlin H., Faigle J.W., Sallmann A., Küng W., Richter W.J., Kriemler H.P., Alt K.O. and Winkler T. - Xenobiotica 9:601 (1979).
6. Schneider W. and Degen P.H. - J. Chromatogr. 217:263 (1981).
7. Schneider W. and Degen P.H. - J. Chromatogr. 383:412 (1986).
8. Sioufi A., Pommier F. and Godbillon J. - J. Chromatogr. 571:87 (1991).